

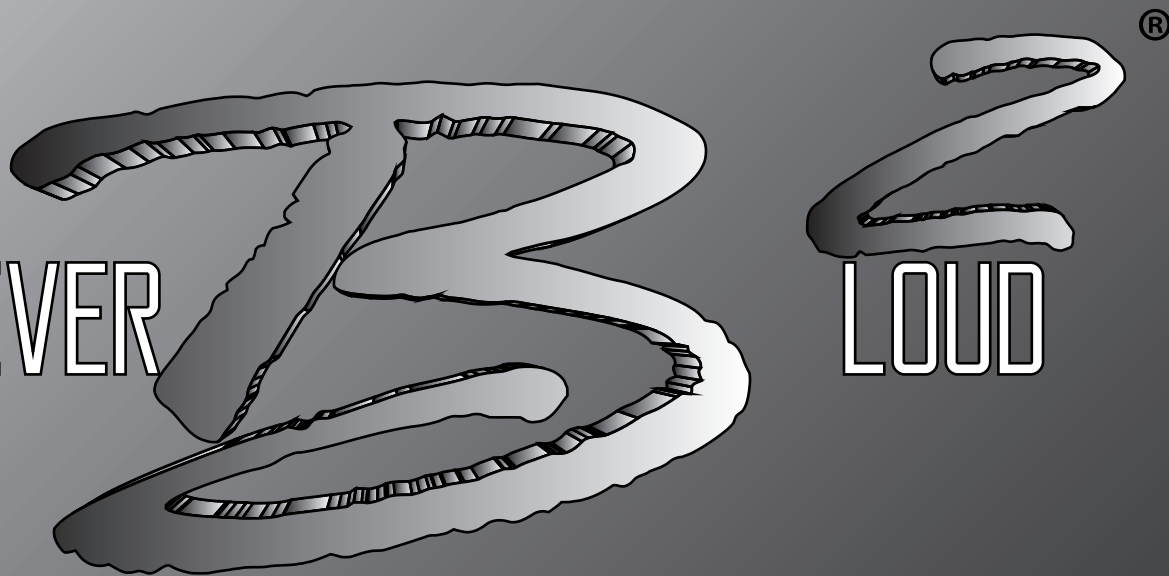

IT CAN NEVER



LOUD

RAGE 1600.5 / RAGE 2300.2 / RAGE 2300.4
USER MANUAL

WWW.B2AUDIO.COM - WWW.FACEBOOK.COM/B2AUDIO - [@B2AUDIOGRAM](https://www.instagram.com/B2AUDIOGRAM)

INTRODUCTION

At times you need to make a statement, differentiating yourself from the masses. Some do so by speech, we do it by product & engineering. Since the beginning of this millenium, we had a vision of pushing the envelope and not settling for less. This reflects the vision and belief in our products, making them stand out from the standard in both appearance & performance. Our products end up in the hands of not only industry professionals, but also the average user, who finds out that what they currently have is not meeting the needs of what they want. We aim for versatility, thus B2 audio is seen worldwide in anything from Sound Quality to Award winning Demobuilds.

RAGE

Don't blow a fuse, keep calm. The next era comes with our redefined levels. The Rage series is "The increased Desire for B2 audio". The Rage should cover any need for near any type of user. Mono, 2 / 4 & 5 channels or even micro size amplification, no problem, Rage covers it all. Enough power and authority refined with the keystones of B2 audio, will provide you with numerous hours of joy and sweetness. The RAGE series amplifiers focus on efficiency, versatility & small footprints for the power output.

To obtain the full potential of any amplifier & to minimize failure, it is advised to upgrade your stock electrical system. Don't take any shortcuts, a better electrical equals enhanced performance and stability.

Stay updated on B2 audio, follow us on social media & visit our website.

www.b2audio.com - www.facebook.com/b2audio - [Instagram.com/b2audiogram](https://www.instagram.com/b2audiogram) - [youtube.com/b2audio](https://www.youtube.com/b2audio) - X:@b2_audio



AUDIOPHILE ACOUSTICS

IS THE DNA OF B2 AUDIO. ANY PRODUCT IS DEVELOPED BY ADDING THE UNIQUENESS AND THOUGHT OF EVOLUTION IN THE SPECIFIC APPLICATION OF THE PRODUCT'S DESIGN.

KEEP IN MIND THAT CONTINUOUS EXPOSURE TO SPL ABOVE 100 DB CAN SERIOUSLY DAMAGE YOUR HEARING. TODAY'S HIGH POWER AUTO SOUND SYSTEMS CAN EASILY PRODUCE SPL ABOVE 140 DB. ENJOY YOUR PASSION WITH SENSE AND RESPECT FOR THE ENVIRONMENT.

TABLE OF CONTENTS

DESIGN SPECIFICATIONS	3	STEREO & BRIDGE CONNECTIONS	7
* POWER OUTPUT		* STEREO 2300.2	7
* DESCRIPTIONS		* BRIDGED 2300.2	8
* BATTERY RECOMMENDATIONS		* STEREO 2300.4	8
PANEL LAYOUT	4	* BRIDGED 2 CH 2300.4	9
POWER & SPEAKER TERMINALS	5	* 3 CH MODE 2300.4	9
		* 5 CH MODE 1600.5	10
		* 3 CH MODE 1600.5	10
INSTALLATION	6	ACCU8 CROSSOVER SETTINGS	11
POWER & SPEAKER CONFIGURATION	7	TROUBLESHOOTING	12
		WARRANTY INFORMATION	13

DESIGN SPECIFICATIONS

MODEL:	RAGE 1600.5	RAGE 2300.4	RAGE 2300.2
CIRCUIT CONFIGURATION:	HI-EF CLASS D	HI-EF CLASS D	HI-EF CLASS D
FREQUENCY RESPONSE:	10 HZ-27 KHZ (CH1-4) 10 HZ-250 HZ (CH 5)	10 HZ-27 KHZ	10 HZ-27 KHZ
SIGNAL TO NOISE RATIO:	>95 DB	>95 DB	>95 DB
INPUT SENSITIVITY:	5 V-0.2 V	5 V-0.2 V	5 V-0.2 V
CROSSOVER CIRCUIT:	24 DB/OCT	24 DB/OCT	24 DB/OCT
LOW PASS CROSSOVER:	50 HZ-5 KHZ (CH-14) 35 HZ-250 HZ (CH 5)	50 HZ-5 KHZ	50 HZ-5 KHZ
HIGH PASS CROSSOVER:	30 HZ-5 KHZ	30 HZ-5 KHZ	30 HZ-5 KHZ
SUBSONIC CROSSOVER:	10 HZ-50 HZ (CH 5)		
PHASE:	0-180 °		
LEVEL CONTROL			
WITH CLIP/VOLT/TEMP:	INCLUDED	OPTIONAL	OPTIONAL
POWER TERMINAL GAUGE:	0 GAUGE / 67 MM ²	0 GAUGE / 67 MM ²	0 GAUGE / 67 MM ²
FUSE RATING:	150 A	250 A	250 A
DIMENSIONS METRIC:	425 x 200 x 70 MM	305 x 200 x 70 MM	305 x 200 x 70 MM
IMPERIAL:	16.73" x 7.87" x 2.75"	12" x 7.87" x 2.75"	12" x 7.87" x 2.75"

CONTINUOUS OUTPUT POWER (RMS) @ 14.4V <1% THD

	4 OHM	2 OHM	4 OHM BRIDGE
RAGE1600.5	<i>4 X 80W + 1 X 350W</i>	<i>4 X 125W + 1 X 600W</i>	<i>2 X 250W + 1 X 1100W (1 OHM MONO)</i>
RAGE2300.4	<i>4 X 450W</i>	<i>4 X 575W</i>	<i>2 X 1150W</i>
RAGE2300.2	<i>2 X 650W</i>	<i>2 X 1150W</i>	<i>1 X 2300W</i>

DESCRIPTIONS OF SPECIFICATIONS

OPERATION BELOW MINIMUM IMPEDANCE WILL STRESS THE AMPLIFIER & VOID THE WARRANTY. EXCESSIVE HEAT WILL OCCUR, CAUSING THE AMPLIFIER TO GO INTO THERMAL PROTECTION. THE CIRCUIT MAY SUSTAIN PERMANENT DAMAGE AND PROTECTION LIGHTS WON'T TURN OFF OR FLASH SEQUENTIALLY. OPERATIONAL VOLTAGE IS FROM 9V TO 17.5V

PROTECTION MAY ALSO BE CAUSED BY THE FOLLOWING

- *INPUT VOLTAGE FROM HEADUNIT BEING TOO HIGH / LOW / POWER SUPPLY VOLTAGE TOO HIGH / LOW.
- *SPEAKER OVERLOAD
- *SHORT CIRCUIT

*FULL OUTPUT POWER ACCORDING TO THE SPEC IS BASED ON A SUFFICIENT ELECTRICAL SUPPLY SYSTEM. IF YOUR SYSTEM IS INADEQUATE, THE EFFICIENCY OF THE AMPLIFIER DECREASES, HURTING THE PERFORMANCE!

THE RAGE1600.5 WILL NEED A DEDICATED AGM BATTERY SUPPLY OF MIN 100 AH AND 1200 CCA. IF YOU ARE USING A COMMON LITHIUM SOURCE OF 6C, A 20 AH LITHIUM BATTERY WILL SUFFICE. THE RAGE2300.4 / 2300.2 WILL NEED A DEDICATED AGM BATTERY SUPPLY OF MIN 150 AH AND 2000 CCA. IF YOU ARE USING A COMMON LITHIUM SOURCE OF 6C, A 30 AH LITHIUM BATTERY WILL SUFFICE.

PANEL LAYOUT

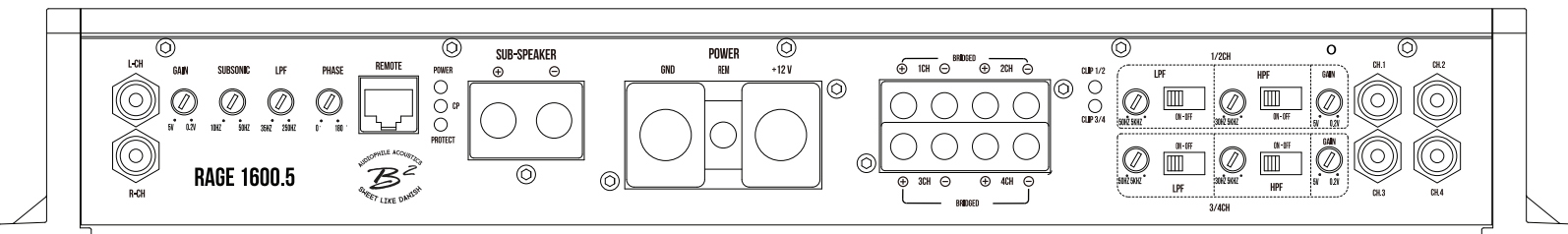
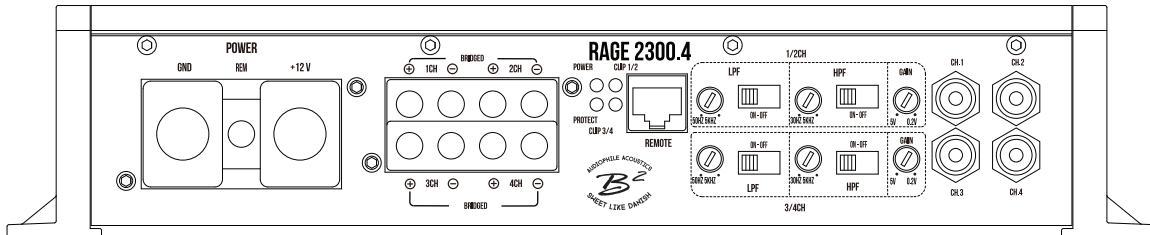
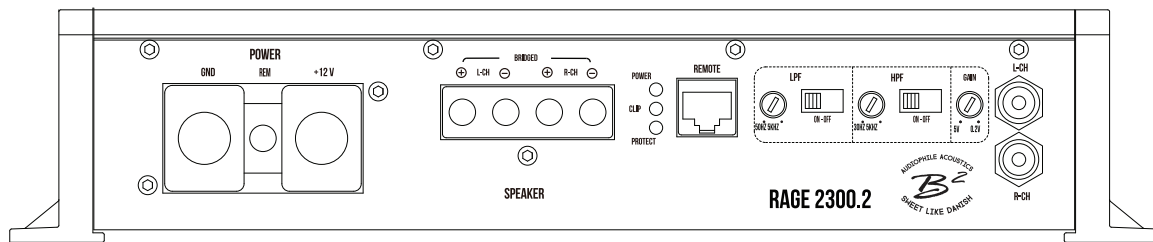

INPUT

RCA signal input for left & right channel.
A minimum of 0.2V input signal is required for correct operation. Using only 1 input will minimize input signal and amplifier will need to be gained as such.

POWER & PROTECTION INDICATOR

Power LED, blue light shows correct operation,
Protect LED, red light shows general malfunction, faulty connection or thermal protection.

CLIP INDICATOR

The LED will light up if signal is clipped. An occasional flashing light is acceptable, a constant lit diode is not.

GAIN (5V~0.2V)

Adjusts signal input voltage from the input source to match the amplifiers input stage.
0.2V ~ 5V is the operational voltage.
Voltages beyond may cause errors or damage to the input section.

SUBSONIC (1600.5 ONLY)

Variable subsonic setting from 10 Hz to 50 Hz.
It is highly recommended to set it according to the tuning of your subwoofer enclosure to avoid unnecessary strain to your sound system.

LPF (LOW PASS FILTER 50 HZ~5KHZ, 24 DB/OCT) /35 HZ ~ 250 HZ

Adjusts the cut off point for the low pass crossover at the frequency chosen.

PHASE (1600.5 ONLY)

Variable phase adjustment from 0 ~ 180°
adjusted in accordance with the amplifiers gain.

HPF (HIGH PASS FILTER 30 HZ~5KHZ, 24 DB/OCT)

Adjusts the cut off point for the high pass crossover at the frequency chosen. Create a BPF by activating both HPF & LPF.

REMOTE

Remote level control port with clip sensor, voltage output and thermal reading.

POWER & SPEAKER TERMINALS

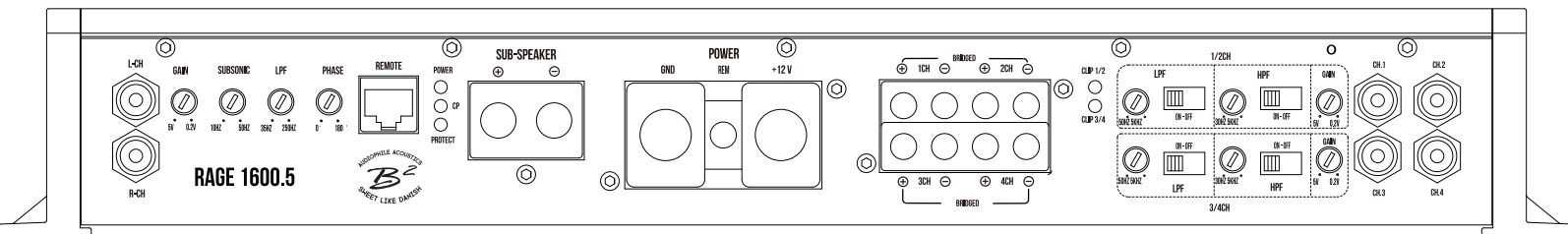
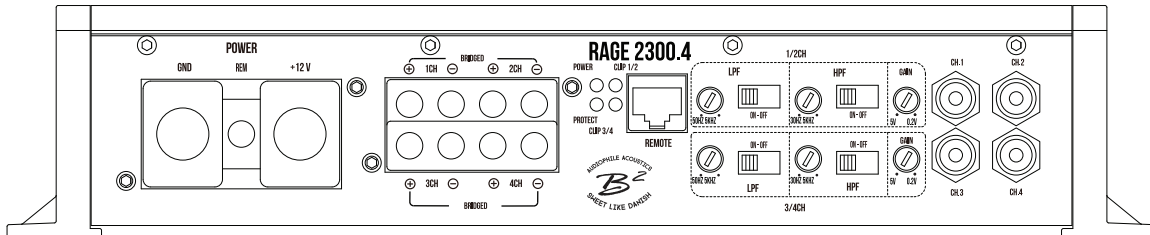
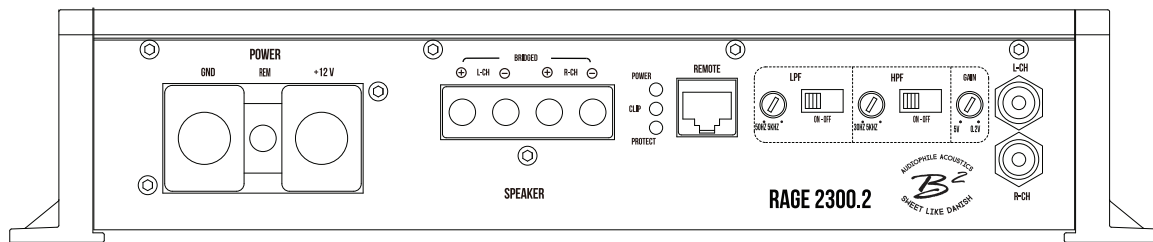

GROUND CONNECTION (GND)

Connect to the vehicle's chassis. Keep as short as possible. Less than 20" / 50 cm for the designated 0 AWG cable.

REM (12V SIGNAL / SWITCHED INPUT)

Run a remote turn on cable from the switched +12 V source. This may be a toggle switch, a relay, the source unit's remote output cable or power antenna trigger cable. Connect the remote turn on cable to the power terminal labeled as REM.

+12V (POWER CONNECTION)

Connects to the positive terminal of the power source. Use minimum 0 AWG to obtain specified performance. Fuses shall be placed within 8" / 20 cm of the battery.

SPEAKER OUTPUT TERMINALS

Ensure the polarity of the cables are correct when connecting the loudspeakers. Use min. 10 AWG cables for the subwoofer connection & min. 14 AWG for the loudspeakers. Only the 1600.5 mono channel is 1 ohm stable. The remaining channels of the amplifiers are stable into 2 ohm stereo.

⚠ CAUTION

INSTALLATION OF THE AMPLIFIER SHALL BE DONE IN THE FOLLOWING STEPS:

1. Connect the +12V wire, keep in mind this wire has to be fused at the battery as well.
2. Ensure the ground is appropriate, then connect it to the amplifier.
3. Connect the switched remote.
4. Reattach negative wire (ground) to the battery.
5. Operation over 17.5V will cause the amplifier to go into protect & can void the warranty!

INSTALLATION

INSTALLATION CONSIDERATIONS

If you choose to install the amplifier by yourself, please read the entire owner's manual carefully. Before you start your installation, please take all steps into consideration. If in doubt, please go to your place of purchase for authorized distributors / dealers that will be able to configure your set up & ensure the warranty of your amplifier.

PREPARATION

Disconnect the negative (-) battery cable before mounting or making any connection. Check the battery & alternator ground (-) connection. Make sure they are properly connected/dimensioned & free of corrosion. Before selecting a mounting location for the amplifier, please take cooling & safety into consideration. Avoid areas with excessive vibration & up side down installation!

In order to avoid excessive heat from the amplifier, it is recommended to find a mounting location that allows for vertical positioning of the heatsink fins. For safety purposes, install the amplifier in a dry and well ventilated location and make sure no cables or other harness of the car is interfaced with the mounting location or will present a hazard to the car's cable, control cables, fuel lines/tanks, hydraulic lines or other components of the vehicle. Route the RCA cables away from high current wires, if possible run RCA, Power and Speaker cables individually and with a good distance from each other.

POWER CONNECTORS

12V (POWER CONNECTION)

Before mounting the amplifier, disconnect the negative (-) wire from the battery to protect any accidental damage to the amplifier or the audio system. The amplifier is equipped with 0 AWG power & ground terminals. It is crucial that all terminals are used with the adequate cable to ensure correct operation. Connect the power cables to the power terminal labeled as +12V.

The amplifier is not equipped with fuses, so external fuses are required at both the battery and the amplifier. Connect one end of the fuse holder to the power cable and the other end of the fuse holder to the positive battery terminal within 8" / 20 cm of the same cable. The same shall be done at the other end of the cable that connects to the amplifier. The fuses will protect the system and the vehicle against the possibility of a short circuit in the power cable. Make sure that the fuses and the fuse holder is according to the system requirements.

GND (GROUND CONNECTION)

Locate a secure grounding connection as close as possible to the amplifier. Make sure the location is clean and provides a direct electrical connection to the chassis of the vehicle. Connect one end of an equal sized cable as the positive cable to the location of ground. It is important that the ground cable is as short as possible, but no longer than 20" / 50 cm at maximum. Run one end of the cable to the grounding point. Run the other end of the cable to the mounting location. Connect the ground cable to the terminals labeled as GND.

REM (REMOTE CONNECTION)

Run a remote turn on cable from the switched +12 V source. This may be a toggle switch, a relay, the source unit's remote output cable or power antenna trigger cable. Connect the remote turn on cable to the power terminal labeled as REM. The REM out terminal is mainly intended for connection of another amplifier ran in a chain, but it can also be used for other units.

INPUT (RCA CABLE)

Run the RCA cables away from the high current cables / speaker cables and connect to the amplifier. Use high quality cables with a secure grounding point to avoid amplifier malfunction and / or alternator whine.

POWER & SPEAKER CONFIGURATION

STEREO

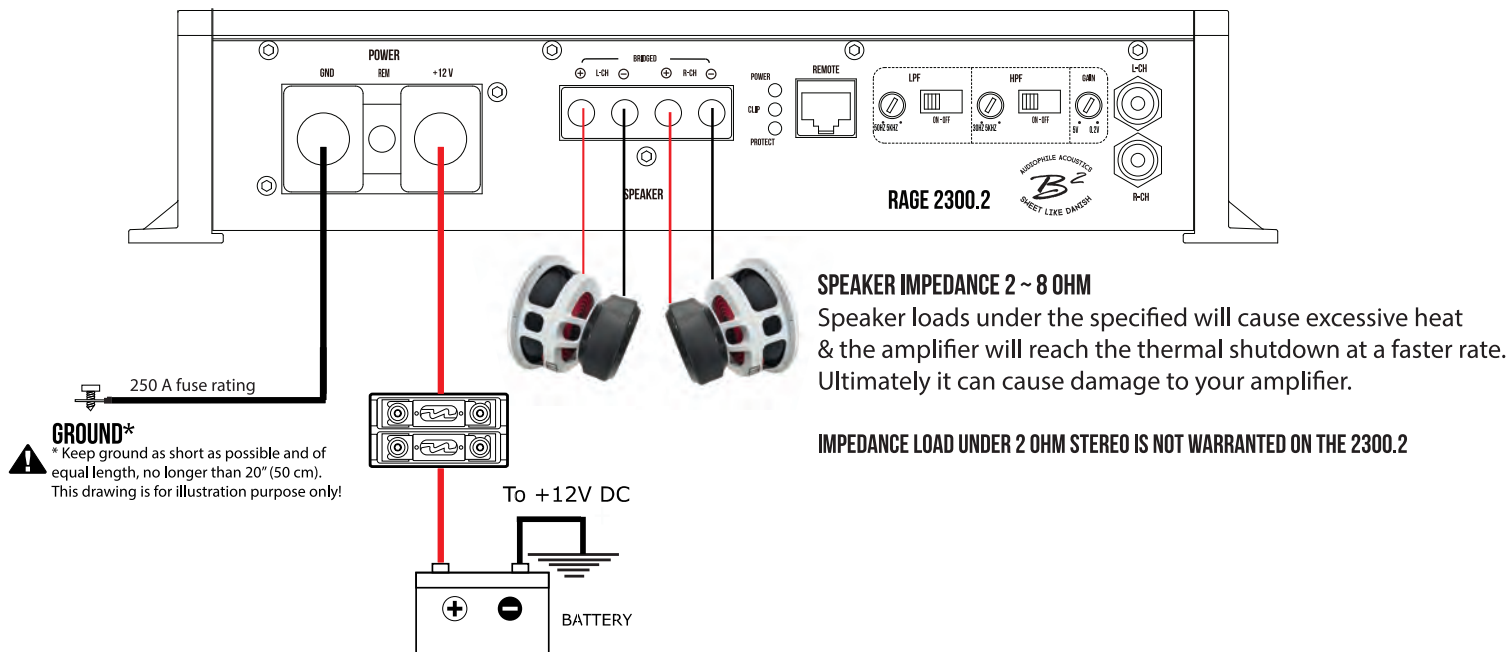

We recommend using minimum 10 Ga speaker cables to acquire the intended performance & efficiency. Run the speaker cables from your speakers to the amplifier's mounting location. Ensure these are ran separately and away from high current cables and if possible the RCA cables as well. In all cases where cables are penetrating the vehicle's chassis use grommets to protect the cable.

Connect the speaker wires according to the terminals on the speaker(s). Strip 3/8" / 1 cm of insulation of the end of each cable and twist the cable strands together tightly. Make sure there are no stray strands that could touch other cables or terminals as it can cause a short circuit. Crimp spade plugs over the end of the cable or tin the ends with solder to provide a solid terminal. Connect the cable ends to the amplifier as shown in the diagram.

⚠ CAUTION

INSTALLATION OF THE AMPLIFIER SHALL BE DONE IN THE FOLLOWING STEPS:

1. Connect the +12V wire, keep in mind this wire has to be fused at the battery as well.
2. Ensure the ground is appropriate, then connect it to the amplifier.
3. Connect the switched remote.
4. Reattach negative wire (ground) to the battery.
5. Operation over 17.5V will cause the amplifier to go into protect & can void the warranty!

POWER & SPEAKER CONFIGURATION

4 OHM BRIDGED

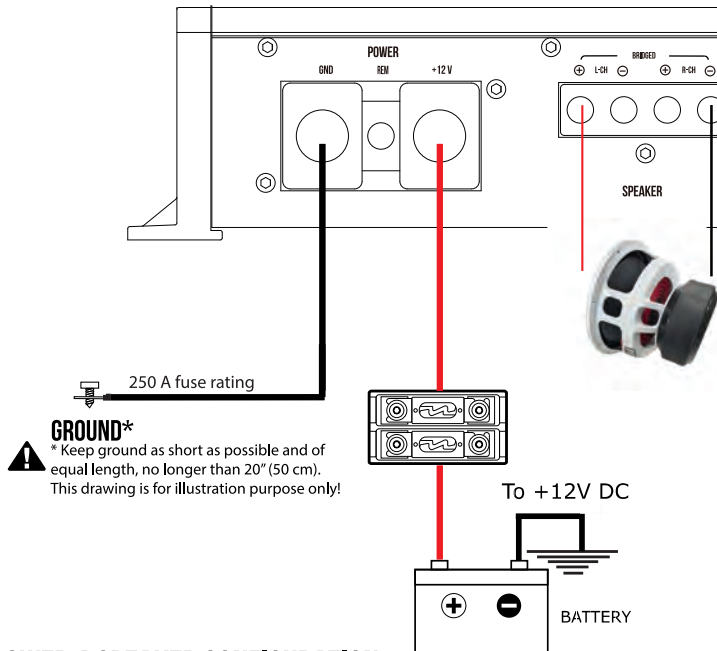

SPEAKER IMPEDANCE 4 ~ 16 OHM

Speaker loads under the specified will cause excessive heat & the amplifier will reach the thermal shutdown at a faster rate. Ultimately it can cause damage to your amplifier.

IMPEDANCE LOAD UNDER 4 OHM BRIDGED IS NOT WARRANTED ON THE 2300.2

GROUND*
* Keep ground as short as possible and of equal length, no longer than 20" (50 cm). This drawing is for illustration purpose only!

POWER & SPEAKER CONFIGURATION

4 OHM STEREO

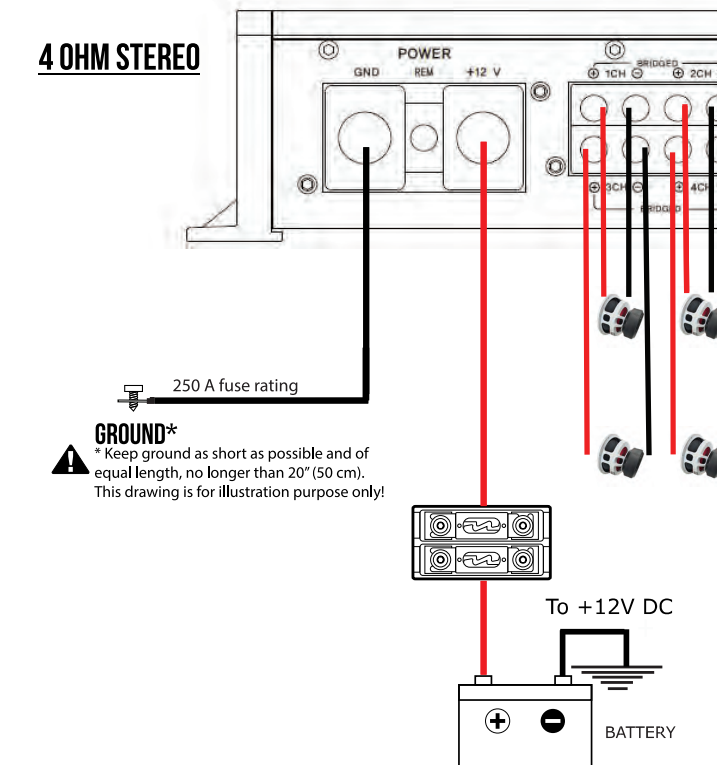

SPEAKER IMPEDANCE 2 ~ 8 OHM

Speaker loads under the specified will cause excessive heat & the amplifier will reach the thermal shutdown at a faster rate. Ultimately it can cause damage to your amplifier.

IMPEDANCE LOAD UNDER 2 OHM STEREO IS NOT WARRANTED ON THE 2300.4

GROUND*
* Keep ground as short as possible and of equal length, no longer than 20" (50 cm). This drawing is for illustration purpose only!

POWER & SPEAKER CONFIGURATION

4 OHM BRIDGED / 2 CH MODE

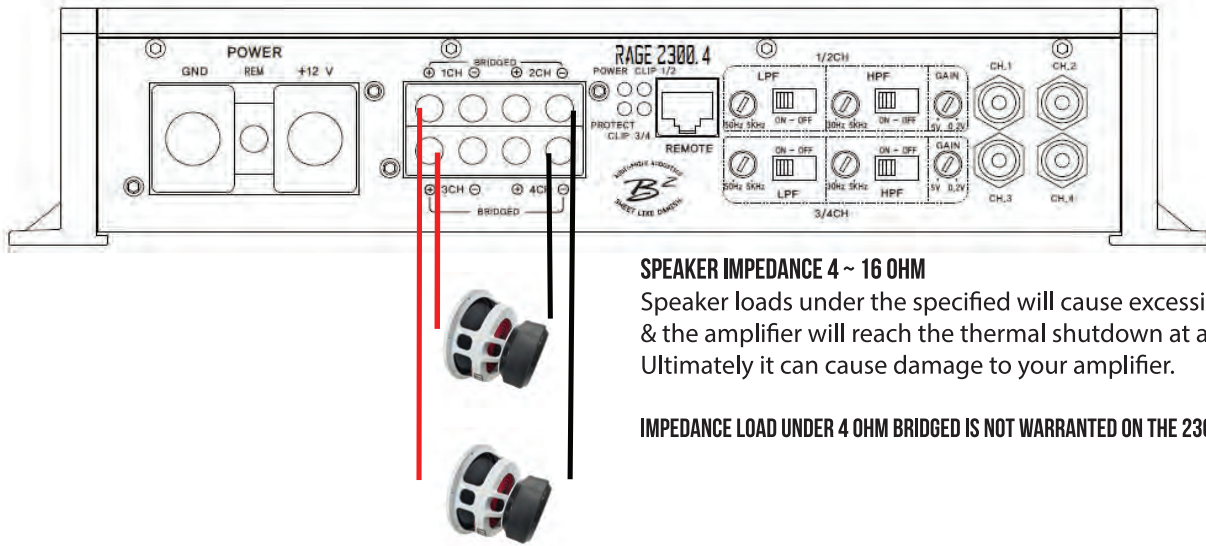

SPEAKER IMPEDANCE 4 ~ 16 OHM

Speaker loads under the specified will cause excessive heat & the amplifier will reach the thermal shutdown at a faster rate. Ultimately it can cause damage to your amplifier.

IMPEDANCE LOAD UNDER 4 OHM BRIDGED IS NOT WARRANTED ON THE 2300.4

POWER & SPEAKER CONFIGURATION

3 CH MODE STEREO + BRIDGED

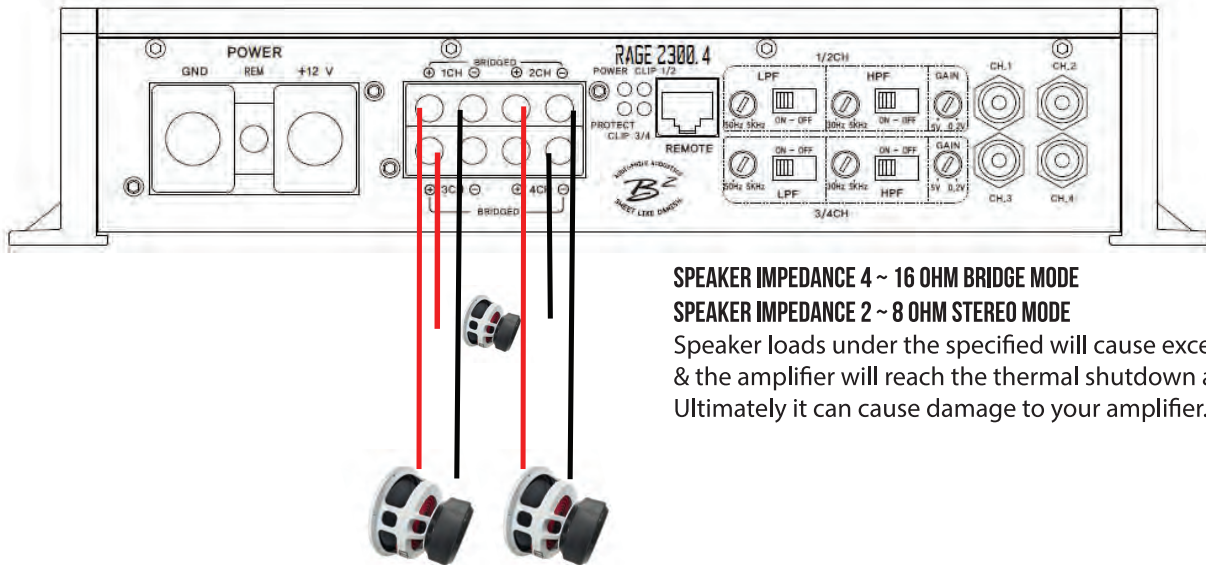

SPEAKER IMPEDANCE 4 ~ 16 OHM BRIDGE MODE

SPEAKER IMPEDANCE 2 ~ 8 OHM STEREO MODE

Speaker loads under the specified will cause excessive heat & the amplifier will reach the thermal shutdown at a faster rate. Ultimately it can cause damage to your amplifier.

POWER & SPEAKER CONFIGURATION

4 CH STEREO + MONO OPERATION

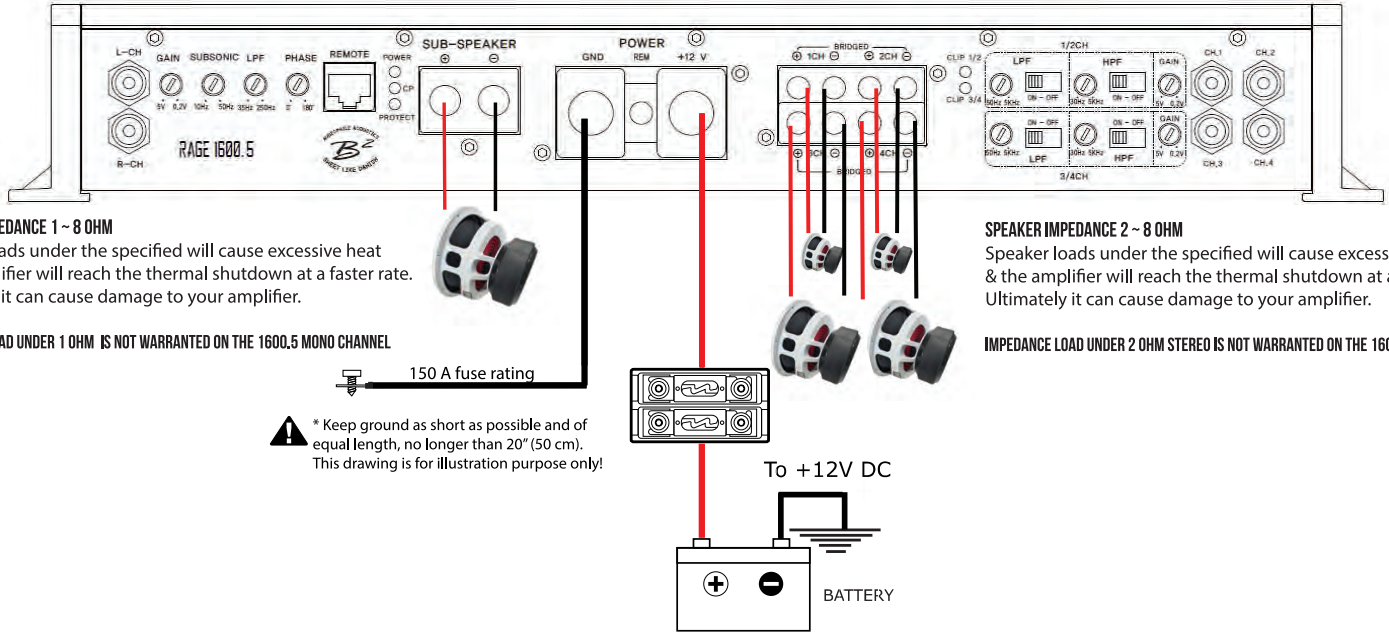

POWER & SPEAKER CONFIGURATION

2 CH BRIDGE + MONO OPERATION

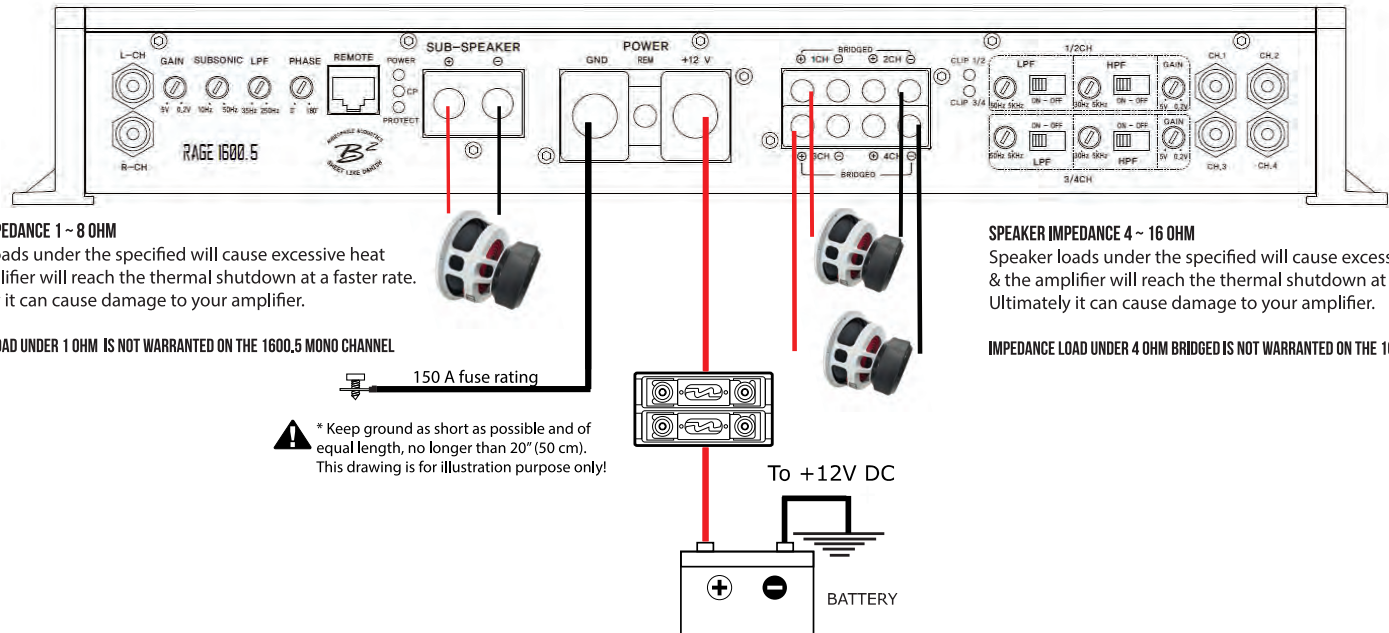

ACCU8 CROSSOVER SETTINGS

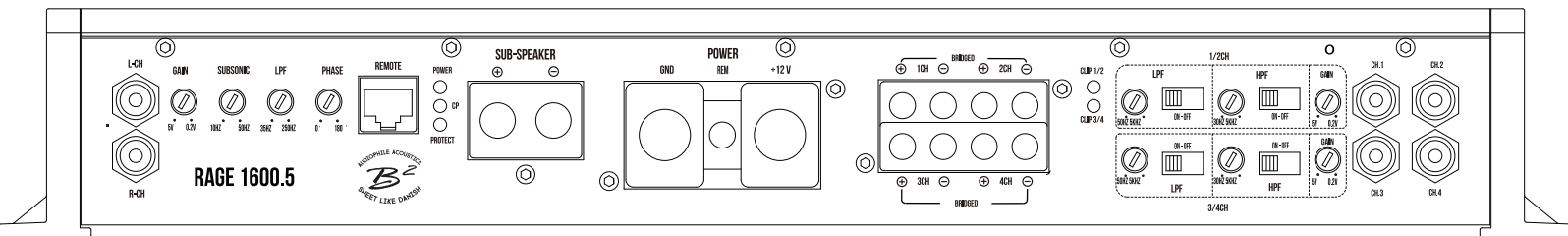
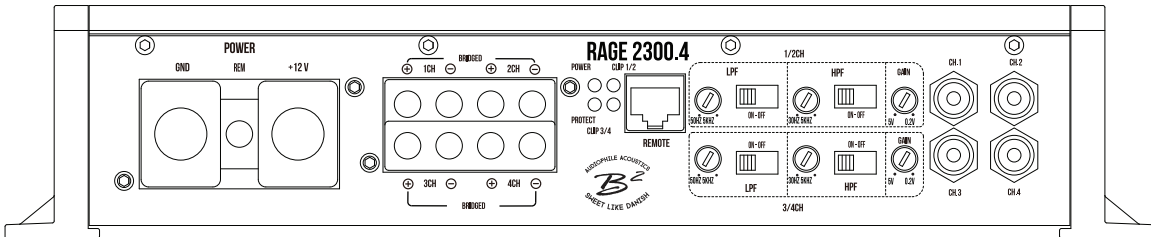
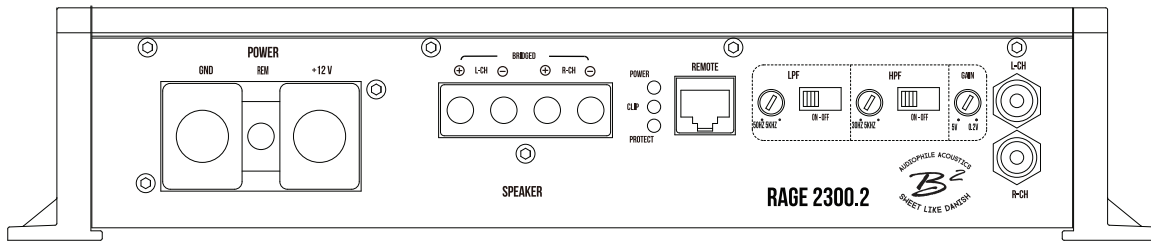

The crossovers on these RAGE amplifier have a 24 dB / oct configuration. Setting it at 80 Hz will then have the signal cut off with 24 dB at 40 Hz (1 octave). To ensure accuracy for the individual crossover frequency, the potentiometer features 41 clicks, each with a corresponding frequency. The chart below is an overview of the clicks.

1600.5 MONO		
step	LPF(Hz)	SUBSONIC (Hz)
1	33	9,50
2	34	9,60
3	34	9,70
4	35	9,80
5	35	10,00
6	36	10,20
7	36	10,40
8	39	11,00
9	41	12,00
10	43	12,50
11	46	13,00
12	50	14,00
13	55	15,00
14	57	16,00
15	61	18,00
16	68	19,50
17	76	23,00
18	86	25,00
19	100	27,00
20	111	29,00
21	116	30
22	120	31
23	125	32
24	130	33
25	135	34
26	140	35
27	144	36
28	151	37
29	160	38
30	170	39
31	181	39,5
32	185	40
33	190	41
34	195	42
35	200	43
36	203	43,8
37	207	44
38	210	44,5
39	230	45
40	240	46
41	250	49

2300.2/2300.4/1600.5		
step	HPF (Hz)	LPF (Hz)
1	30	51
2	31	52
3	32	53
4	33	54
5	34	55
6	35	56
7	36	57
8	38	59
9	40	62
10	42	66
11	45	72
12	48	75
13	54	84
14	58	89
15	64	101
16	76	116
17	90	136
18	110	164
19	140	210
20	160	250
21	192	280
22	205	300
23	220	320
24	235	342
25	254	370
26	280	415
27	305	440
28	375	530
29	430	600
30	480	690
31	650	900
32	810	1.1K
33	940	1.25K
34	1.3K	1.5K
35	1.45K	1.8K
36	2K	2.45K
37	3K	3.5K
38	3.5K	4K
39	4.5K	4.7K
40	4.9K	4.9K
41	5K	5.1K

TROUBLESHOOTING

The protection circuits of the amplifier prevents severe damages from faulty conditions & improper use. The protection indicator will switch on due to short circuit connection & speaker overload, thus the amplifier will be turned off. Prior to inspecting the occurred problem, turn all levels down & all power off, then carefully check the installation for wiring mistakes, shorts or faulty ground (GND). If the amplifier shuts down due to excessive heat, the protection indicator will light up; please allow time for the unit to be cooled off. Before removing your amplifier, refer to the list below and follow the suggested procedures step by step. If not at ease, contact an authorized installer which can assist you.

AMPLIFIER DOESN'T TURN ON

- Measure voltage on the +12V terminal.
- Ensure that the remote terminal has min. 13.8 V DC remote connection.
- Recheck the ground (GND) connection. Inspect the in-line fuses.
- Check the protection LED is not on.

PROTECTION LED IS LIT ONCE THE AMPLIFIER IS TURNED ON

- Check shorts on speaker wires & the connected load / impedance. Check power cables & GND.
- Disconnect the speaker cables and reset the amplifier.
- High / Low voltage, operation voltage is 9.5 V~17.5v. Voltages below / beyond this will cause the amplifier to go into protect.

FUSE BLOWING

- Measure the speaker impedance & that it is in accordance with the configuration.
- Inspect the power cable for shorts along with vehicle chassis.

OVERHEATING

- Measure the speaker impedance & that it is in accordance with the configuration.
- Check speaker shorts.
- Ensure airflow around the amplifier is sufficient & that the amplifier is not installed in areas of excessive vibration & upside down!

AUDIO OUTPUT INSUFFICIENT - DISTORTED SOUND

- Ensure that the gain settings on the amplifier is matched with the output level of the head unit.
- Adjust the head unit volume.
- Check speaker shorts.
- Adjust the crossover frequencies in accordance with the setup.
- If no output at all, check the RCA connections & the cable itself.

TURN ON THUMP

- Disconnect the signal input to the amplifier, then turn it on and off.
 - a) If the noise is cancelled, then connect a delay turn on module on the REM wire running from the source unit to the amplifier.
 - b) Use another 12V source for REM lead to the amplifier. If the noise is cancelled, use a relay to isolate the amplifier from the turn on thump.

HIGH HISS - ALTERNATOR WHINE

- Ensure that all signal transferring wires (RCA, speaker cables etc) are kept separately / away from the power and the ground wires.
- Bypass all electrical components between the Head unit and the amplifier.
Connect the Head unit directly to the amplifier's input. If the noise is eliminated, the unit bypassed is the one causing the noise.
- Remove the existing ground wires for all electrical components installed. Ensure that the point of ground is 100% metal which has been grinded free of rust, paint etc.
- Replace the ground cable from the OEM battery / alternator and ensure it is grounded accordingly.
- Test the battery and alternator load (can be carried out by a professional).
Ensure that the vehicle's electrical system is in a good condition, this includes distributor, alternator, spark plugs / wires, voltage regulators etc.

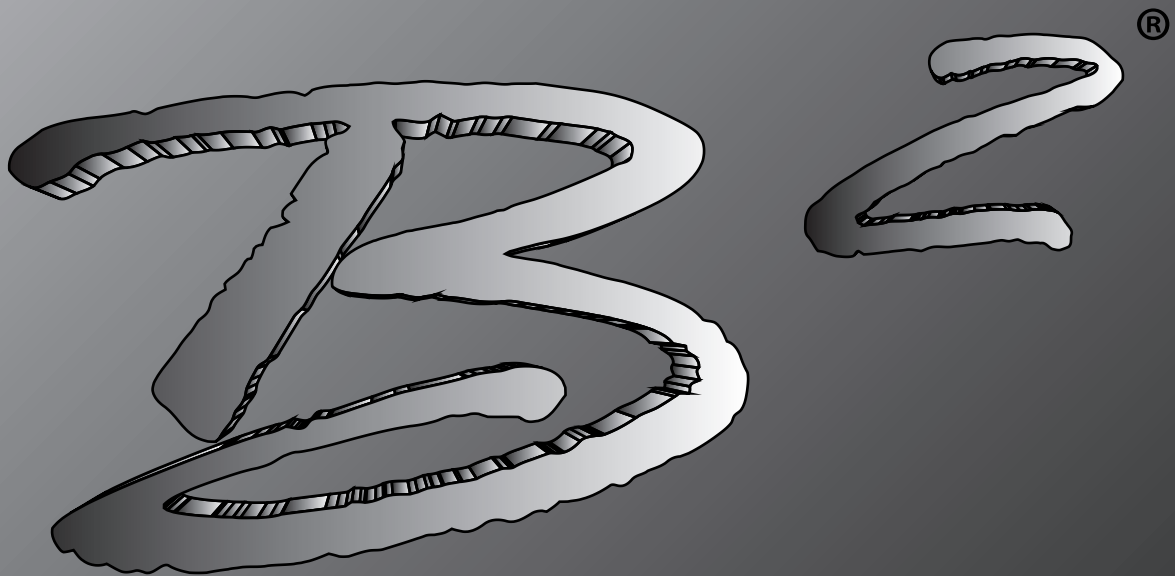

LIMITED WARRANTY INFORMATION

B2 audio offers a limited warranty under the following terms:

The product is to be free of defects in material & workmanship under normal use for a period of 1 year from the date of the original purchase, when installed by an authorized dealer. Items not installed by authorized dealers will be warrantied for 30 days from the original purchase. Original sales receipts must be accompanied with all returns. The warranty applies to the original purchaser of the product & it being sold by authorized B2 audio dealers.

The warranty does not cover: 1. Damage caused by accident, abuse, misuse, improper operation, water / solvents & shipping.

2. Product modification, neglect, failure to follow installation instructions & misrepresentation by the seller.

3. Products used for competition purposes or are of such a character 4. Any product that has been opened.

5. Products that has had the serial number defaced, altered or removed.

6. The cost of shipping the product back for repair to an authorized repair centre & cost of return of non-defective items.